

PREPARED FOR:



Town of Swampscott
22 Monument Ave.
Swampscott, MA 01907-197
781-596-8850

SWAMPSCOTT WATERFRONT ACCESS PLAN

SWAMPSCOTT, MA

PREPARED BY:



214 CAMBRIDGE STREET | FIFTH FLOOR
BOSTON, MA 02114
617.227.2560
info@klopferteam.com

DRAWING INDEX

#	DRAWING TITLE
--	COVER SHEET
L1.1	NEW OCEAN BEACH EXISTING CONDITIONS
L1.2	WHALE'S BEACH EXISTING CONDITIONS
L1.3	EISMAN'S BEACH EXISTING CONDITIONS
L2.1	NEW OCEAN BEACH DEMO AND SITE PREP PLAN
L2.2	WHALE'S & EISMAN'S BEACH DEMO AND SITE PREP PLAN
L3.1	NEW OCEAN BEACH MATERIALS PLAN
L3.2	WHALE'S & EISMAN'S BEACH MATERIALS PLAN
L4.1	DETAILS

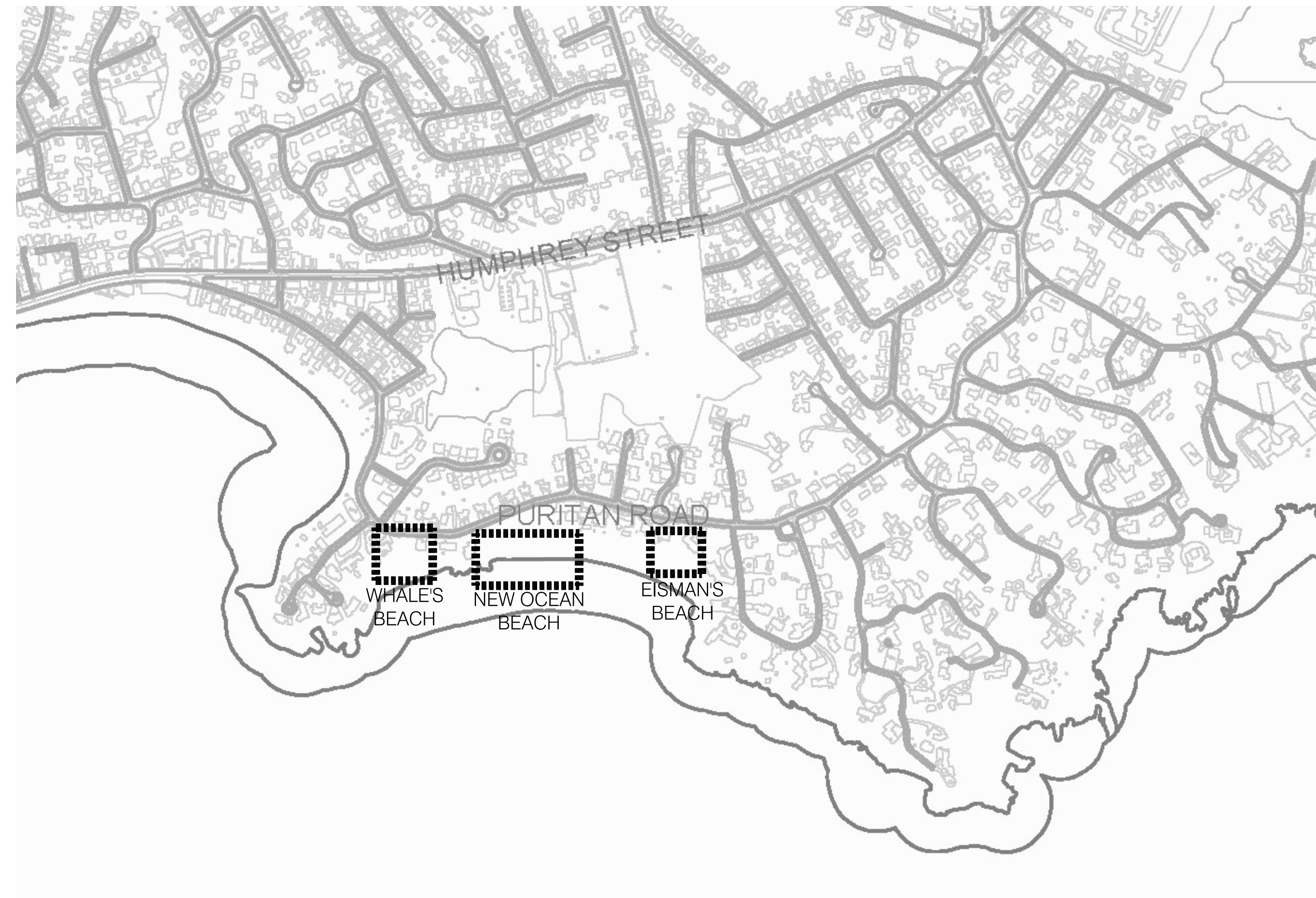

PROJECT SITE (NOT TO SCALE)



LOCUS MAP (NOT TO SCALE)

ABBREVIATIONS LIST:

ADJ	ADJACENT
AGG	AGGREGATE
BC	BOTTOM OF CURB
BIT	BITUMINOUS
BETW	BETWEEN
BS	BOTTOM OF STEP
BW	BOTTOM OF WALL
CLF	CHAIN LINK FENCE
CB	CATCH BASIN
CIP	CAST IN PLACE
CONC	CONCRETE
CP	CENTER POINT
DETL	DETAIL
DIA	DIAMETER
DIM	DIMENSION
DWG	DRAWING
EA	EACH
EHH	ELECTRIC HAND HOLE
EQ	EQUAL
EXP	EXPANSION
EX	EXISTING
FIN	FINISH
GA	GALVE
GALV	GALVANIZED
GRAN	GRANITE
HT	HEIGHT
JT	JOINT
LA	LANDSCAPE ARCHITECT
LP	LIGHT POLE
MAT'L	MATERIAL
MAX	MAXIMUM
MH	MANHOLE
MIN	MINIMUM
MTD	MOUNTED
NTS	NOT TO SCALE
OC	ON CENTER
OD	OUTSIDE DIAMETER
PC	POINT OF CURVATURE
PCS	PIECES
POB	POINT OF BEGINNING
PSF	POUNDS PER SQUARE FOOT
PSI	POUNDS PER SQUARE INCH
PT	PRESSURE TREATED
PTD	PAINTED
PVMT	PAVEMENT
REINF	REINFORCED
REQ	REQUIRED
SF	SQUARE FEET
SHT	SHEET
SIM	SIMILAR
STL	STEEL
TC	TOP OF CURB
TS	TOP OF STEP
TW	TOP OF WALL
TYP	TYPICAL
VERT	VERTICAL
VGC	VERTICAL GRANITE CURB
VIF	VERIFY IN FIELD
WWM	WELDED WIRE MESH
WG	WATER GATE

100% SET - 06/07/19

CALL "DIGSAFE" AT
LEAST 72 HOURS IN ADVANCE OF CONSTRUCTION AT
1-888-DIG-SAFE OR 1-888-344-7233

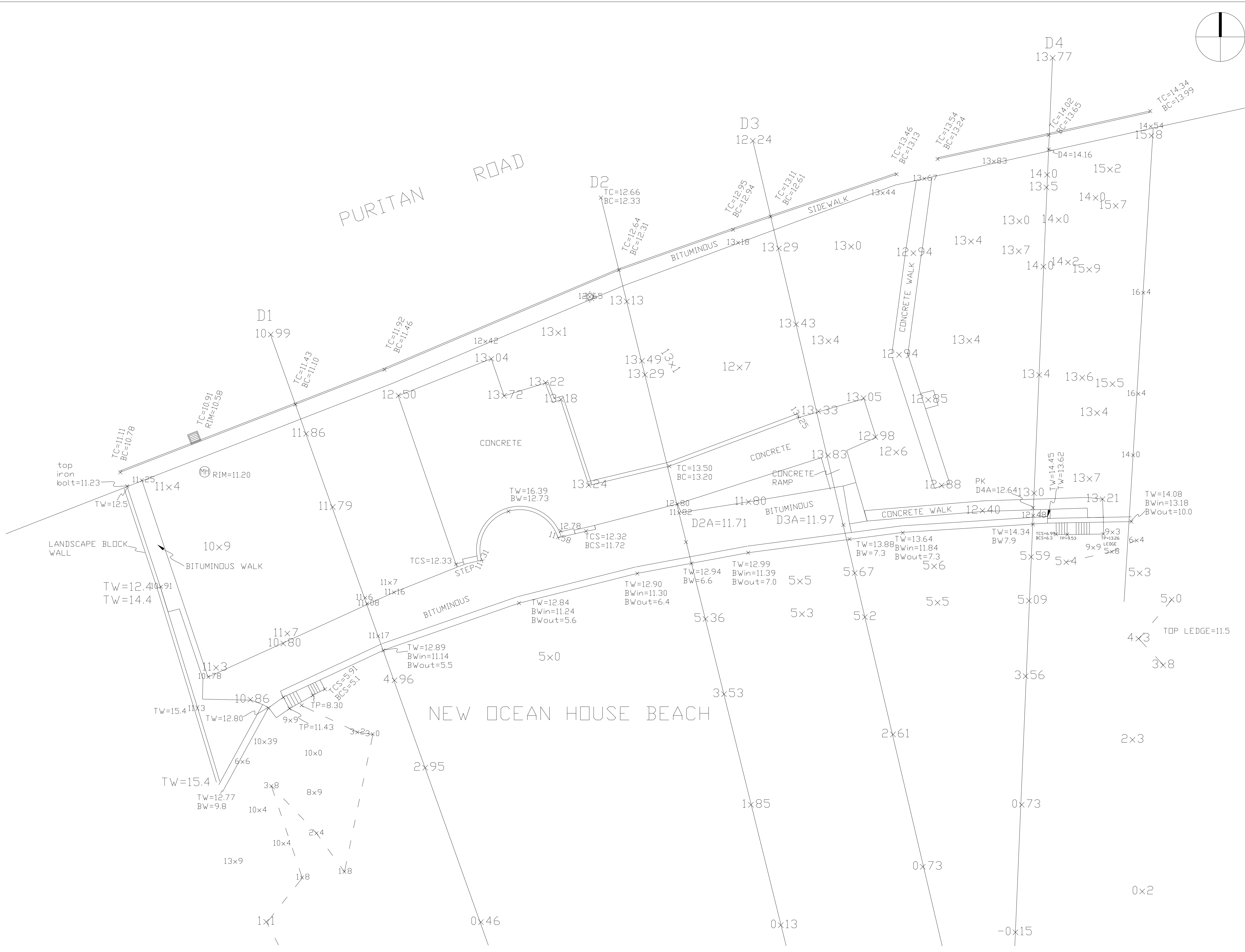
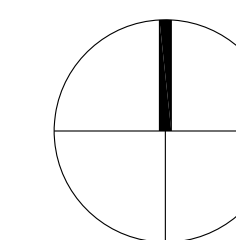

CLIENT:

TOWN OF SWAMPSCOTT

22 MONUMENT AVE.
SWAMPSCOTT, MA, 01907

REVISIONS:

REV DATE NOTE

PROJECT:
SWAMPSCOTT WATERFRONT ACCESS PLAN

PURITAN ROAD
SWAMPSCOTT, MA, 01907

DRAWING:

NEW OCEAN BEACH EXISTING CONDITIONS

DRAWN: LP REVIEW: MK

SCALE:
1/16" = 1'-0"

DATE:
07 JUNE 2019

SHEET:

L1.1

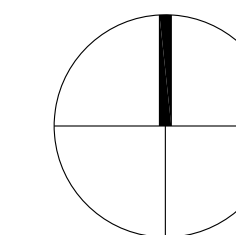

CLIENT:

TOWN OF SWAMPSCOTT

22 MONUMENT AVE.
SWAMPSCOTT, MA, 01907

REVISIONS:

REV	DATE	NOTE

PROJECT:
SWAMPSCOTT WATERFRONT ACCESS PLAN

PURITAN ROAD
SWAMPSCOTT, MA, 01907

DRAWING:

EISMAN'S BEACH EXISTING CONDITIONS

DRAWN: LP	REVIEW: MK
--------------	---------------

SCALE:
1/16" = 1'-0"

DATE:
07 JUNE 2019

SHEET:

L1.3

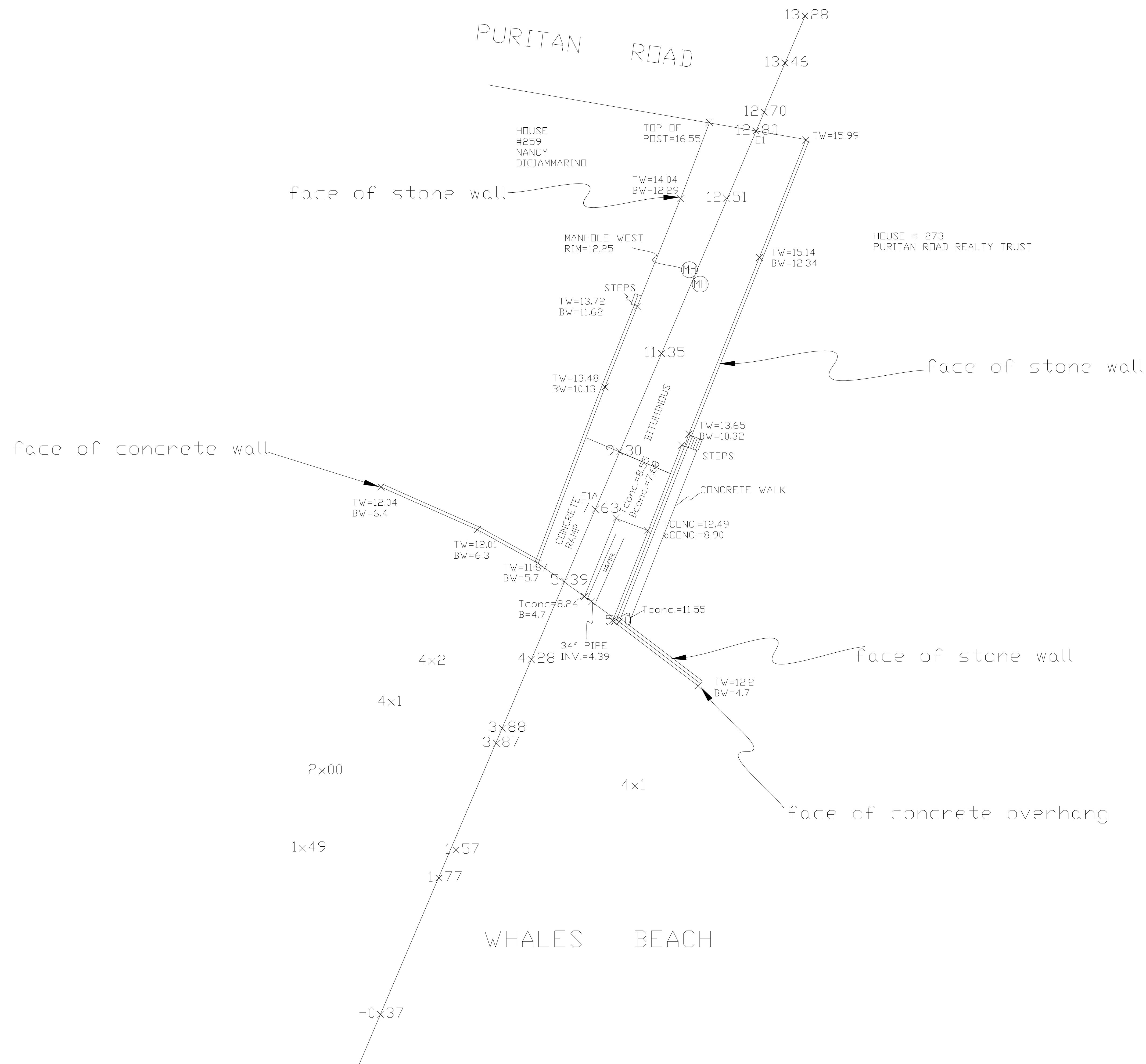

CLIENT:

TOWN OF SWAMPSCOTT

22 MONUMENT AVE.
SWAMPSCOTT, MA, 01907

REVISIONS:

REV DATE NOTE

PROJECT:
SWAMPSCOTT WATERFRONT ACCESS PLAN

PURITAN ROAD
SWAMPSCOTT, MA, 01907

DRAWING:

NEW OCEAN BEACH DEMO AND SITE PREP PLAN

DRAWN: LP REVIEW: MK

SCALE: AS NOTED

DATE: 07 JUNE 2019

SHEET:

L2.1

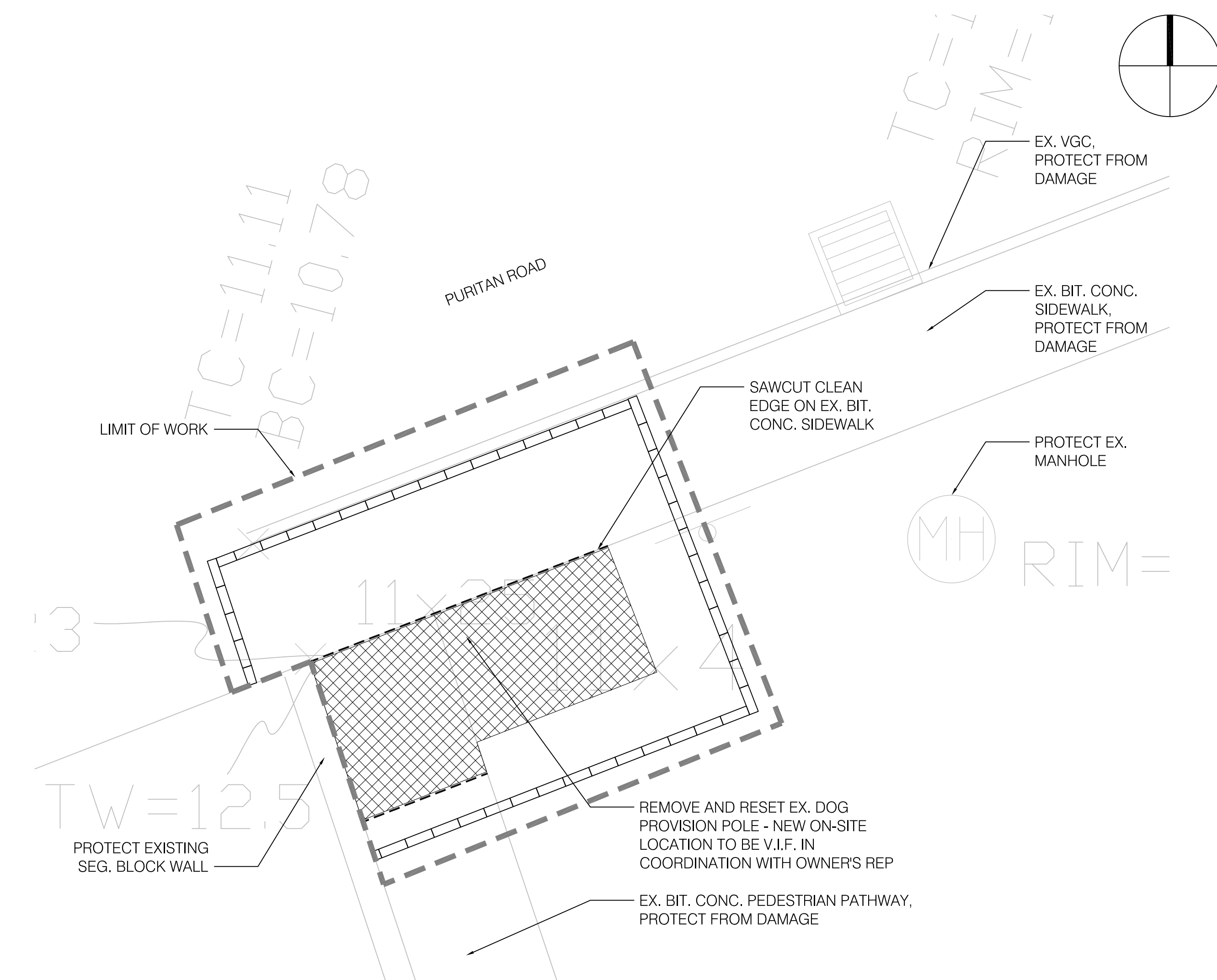

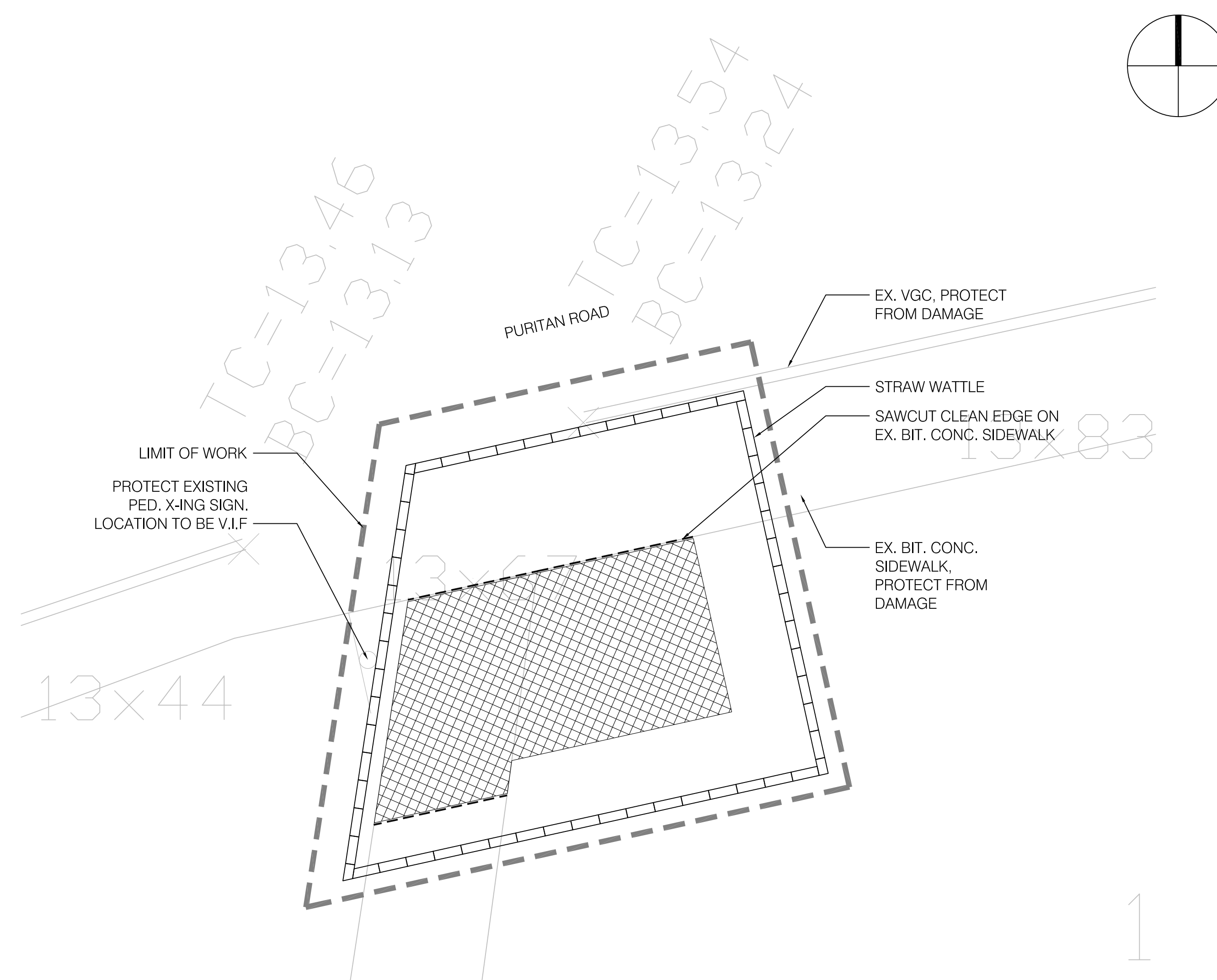

1 NEW OCEAN BEACH LOCATION
SCALE: 1/4" = 1'-0"

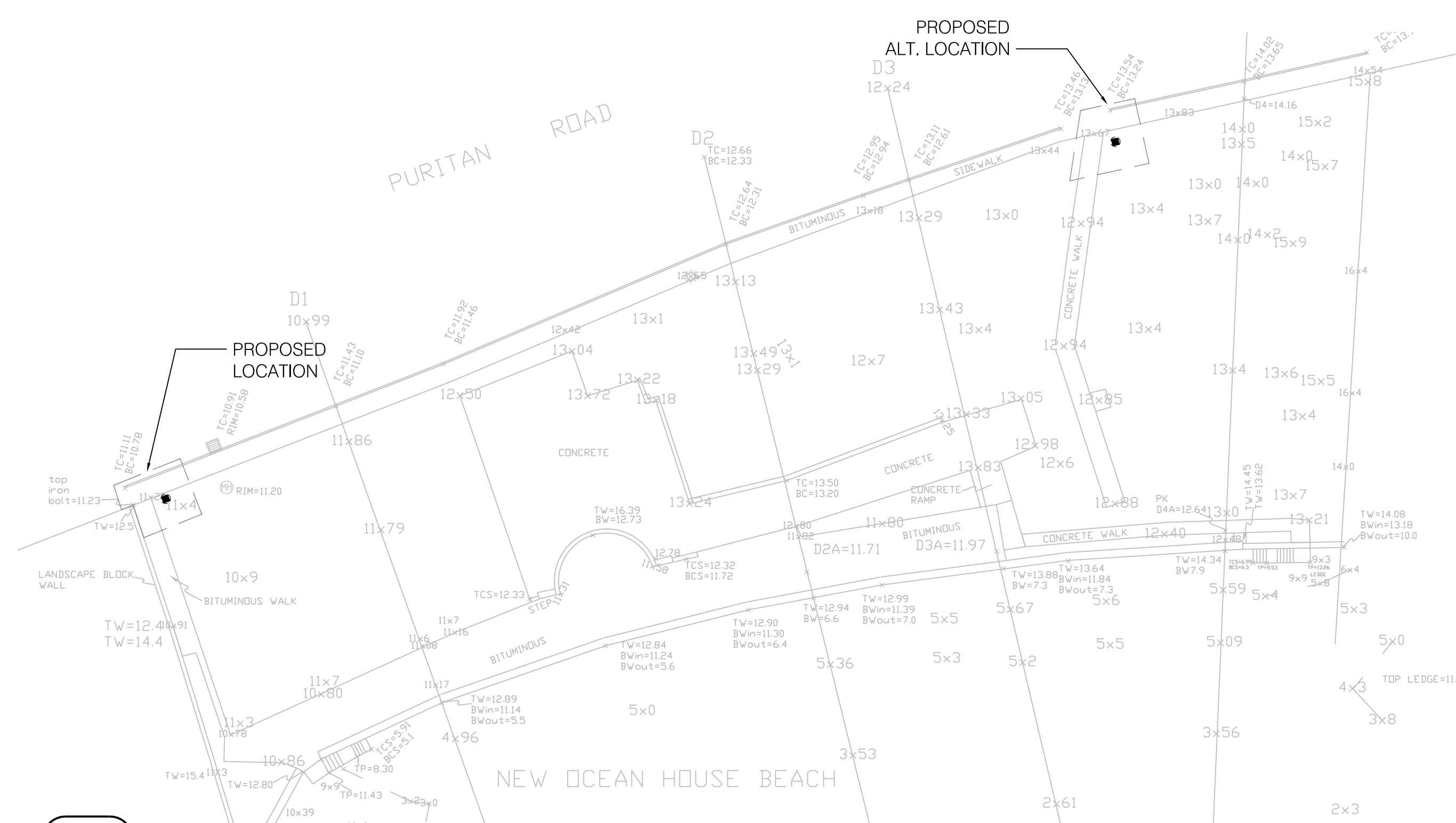

2 NEW OCEAN BEACH ALT. LOCATION
SCALE: 1/4" = 1'-0"

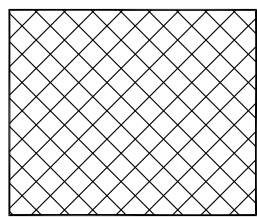
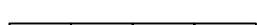

3 NEW OCEAN BEACH
SCALE: 1/32" = 1'-0"

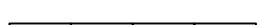
- LEGEND**
-  REMOVE AND DISPOSE
 -  SAWCUT LIMIT
 -  LIMIT OF WORK
 -  STRAW WATTLE

CLIENT:

TOWN OF SWAMPSCOTT

22 MONUMENT AVE.
SWAMPSCOTT, MA, 01907

REVISIONS:

REV	DATE	NOTE

PROJECT:
SWAMPSCOTT WATERFRONT ACCESS PLAN

PURITAN ROAD
SWAMPSCOTT, MA, 01907

DRAWING:

WHALE'S & EISMAN'S BEACH DEMO AND SITE PREP PLAN

DRAWN: LP REVIEW: MK

SCALE:
AS NOTED

DATE:
07 JUNE 2019

SHEET:

L2.2

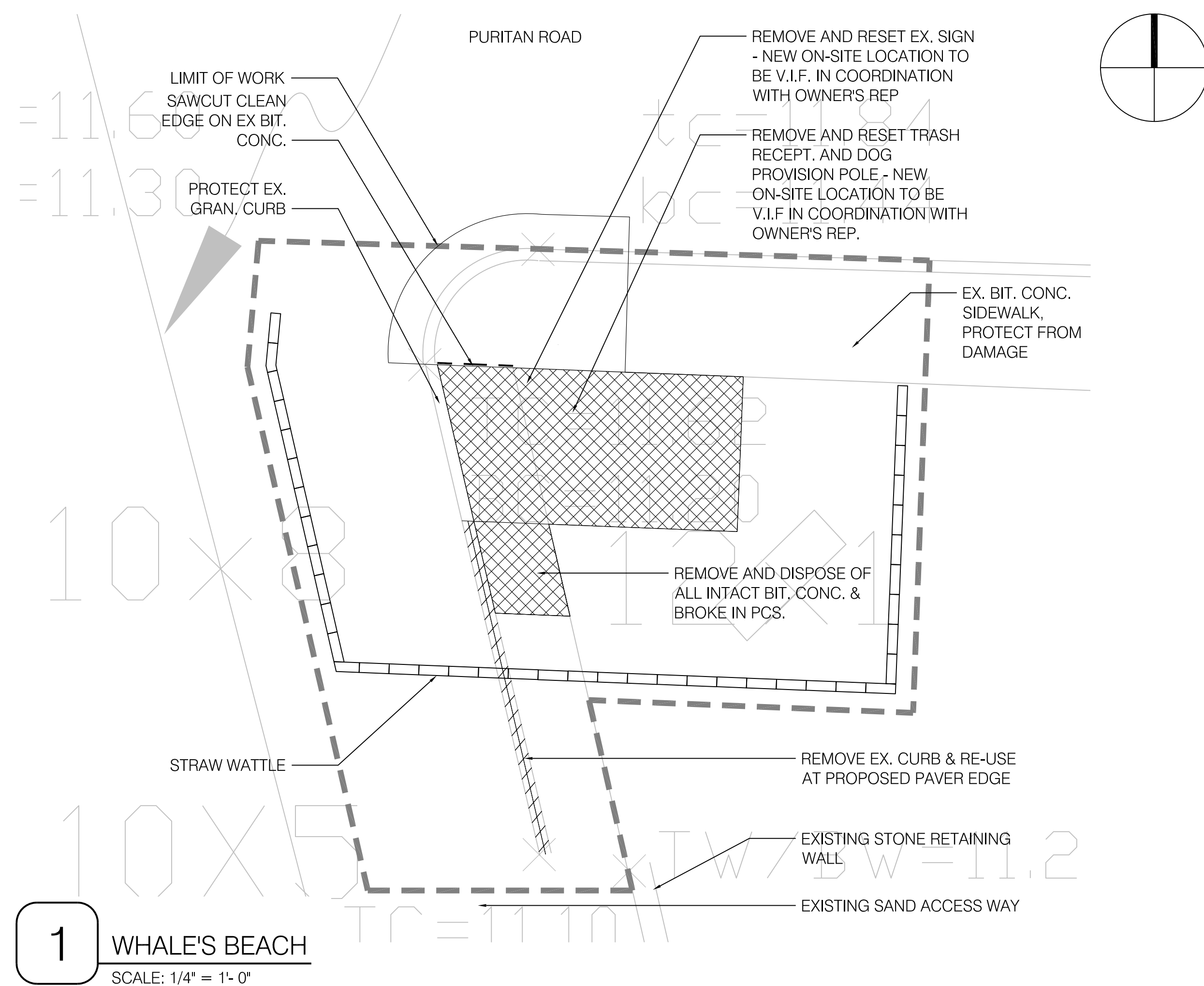

1 WHALE'S BEACH
SCALE: 1/4" = 1'-0"

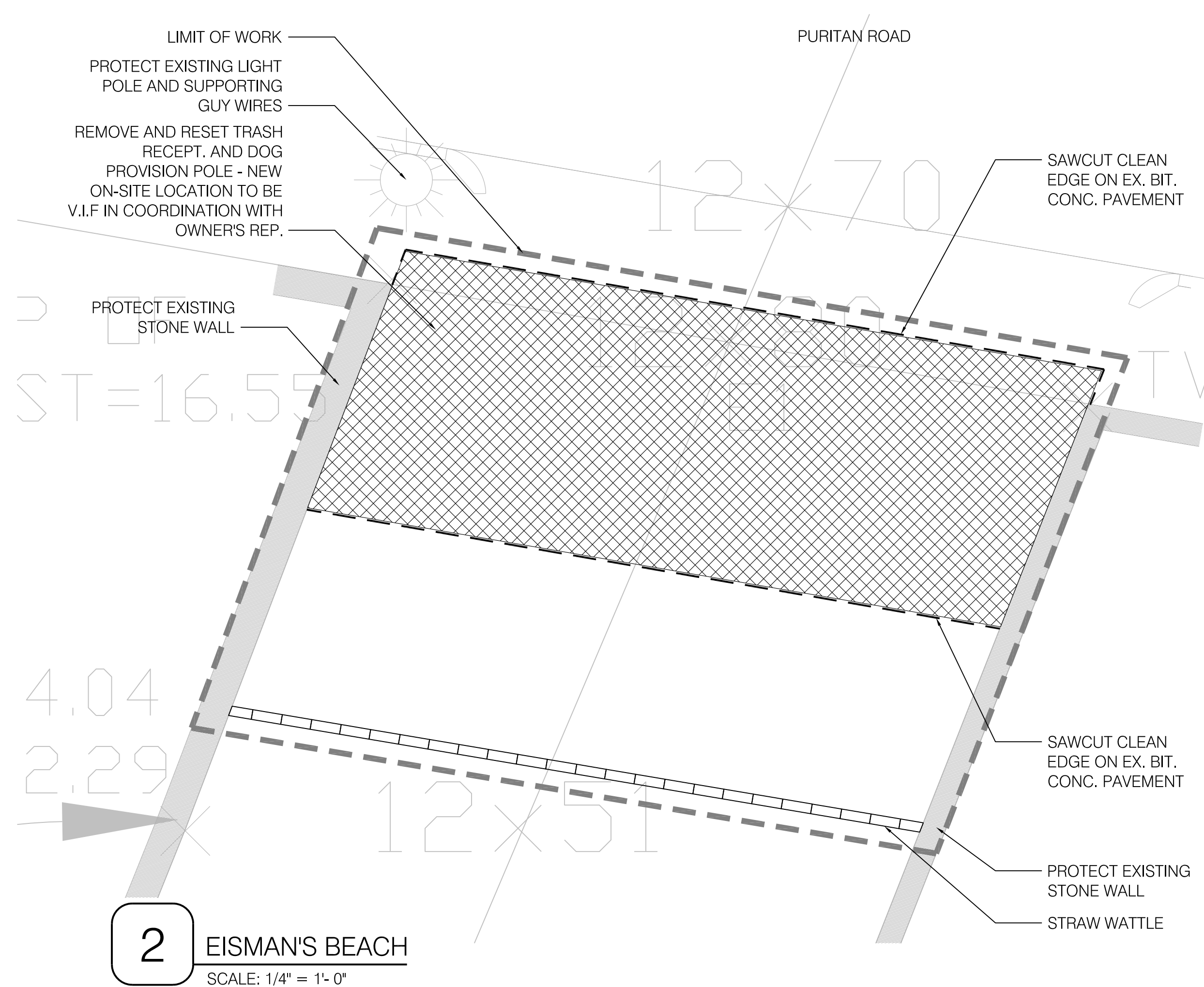

2 EISMAN'S BEACH
SCALE: 1/4" = 1'-0"

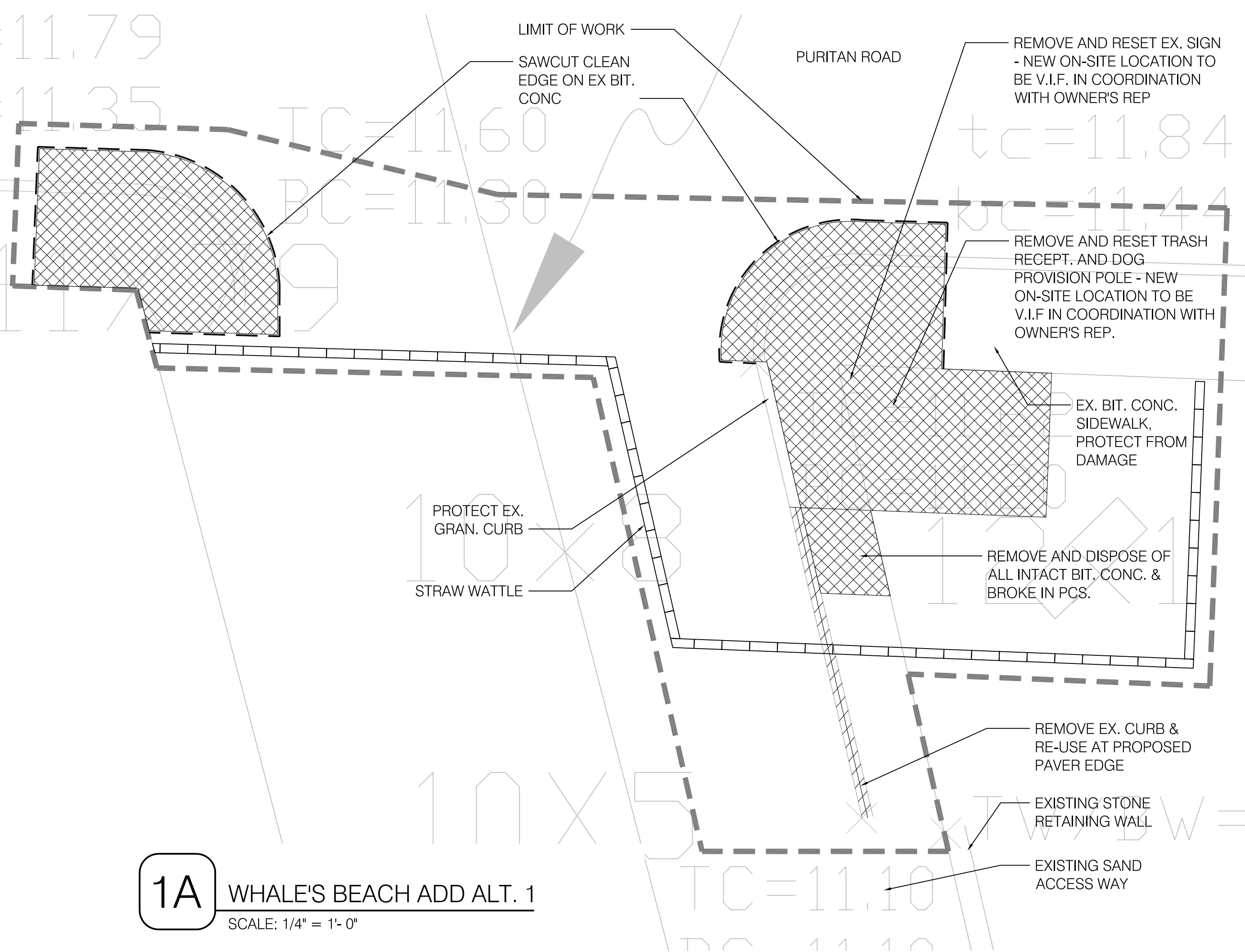

1A WHALE'S BEACH ADD ALT. 1
SCALE: 1/4" = 1'-0"

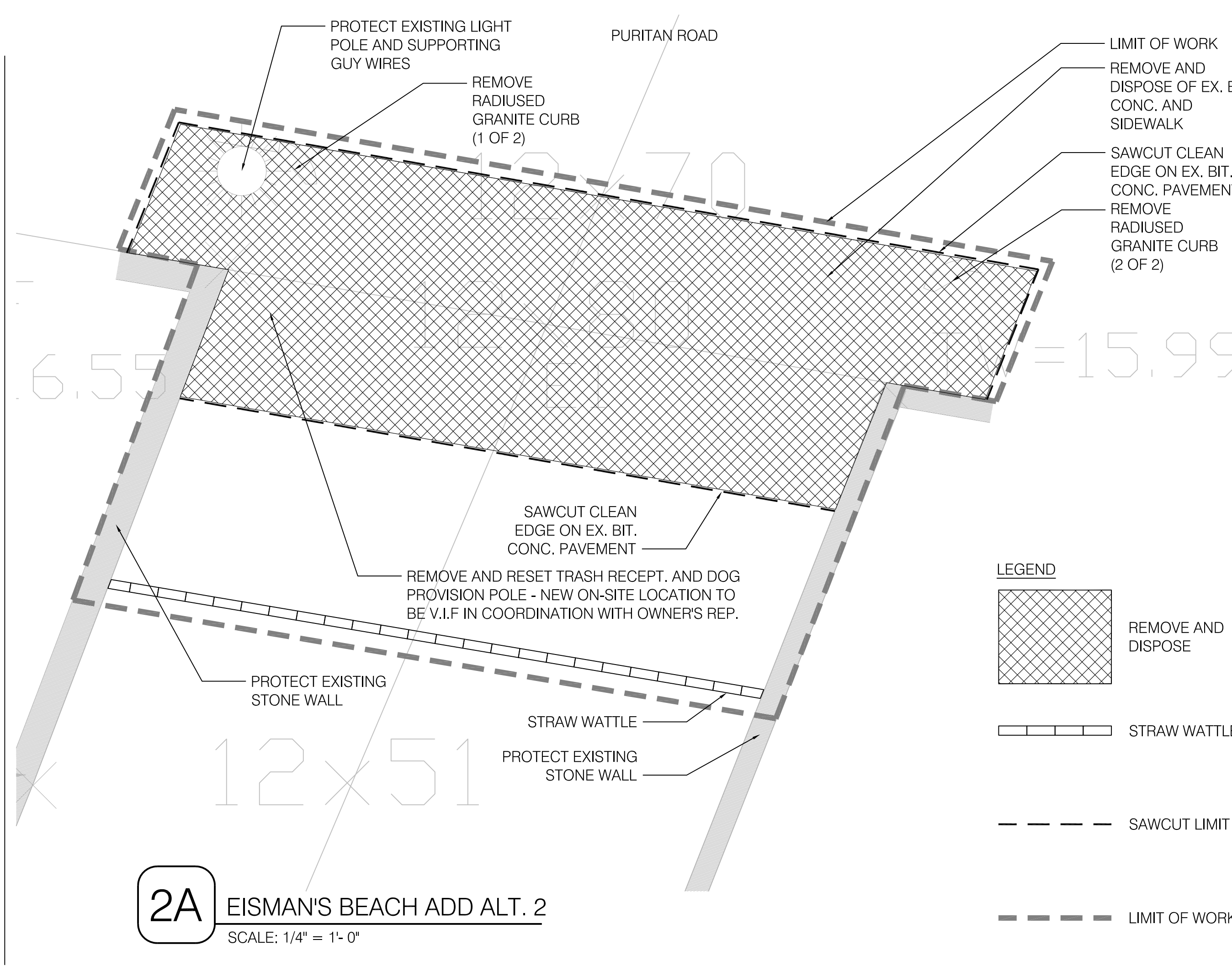

2A EISMAN'S BEACH ADD ALT. 2
SCALE: 1/4" = 1'-0"

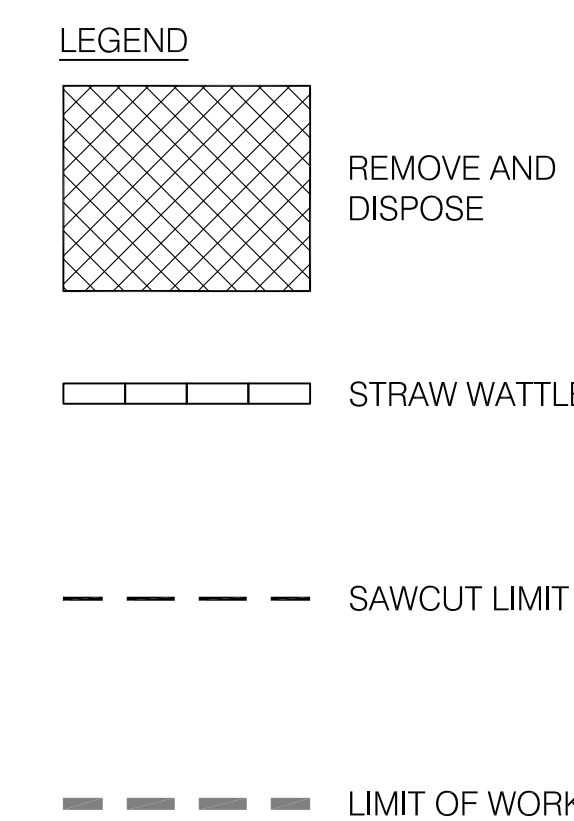

CLIENT:

TOWN OF SWAMPSCOTT

22 MONUMENT AVE.
SWAMPSCOTT, MA, 01907

REVISIONS:

REV	DATE	NOTE

PROJECT:
SWAMPSCOTT WATERFRONT ACCESS PLAN

PURITAN ROAD
SWAMPSCOTT, MA, 01907

DRAWING:

NEW OCEAN BEACH MATERIALS PLAN

DRAWN: LP REVIEW: MK

SCALE: AS NOTED

DATE: 07 JUNE 2019

SHEET:

L3.1

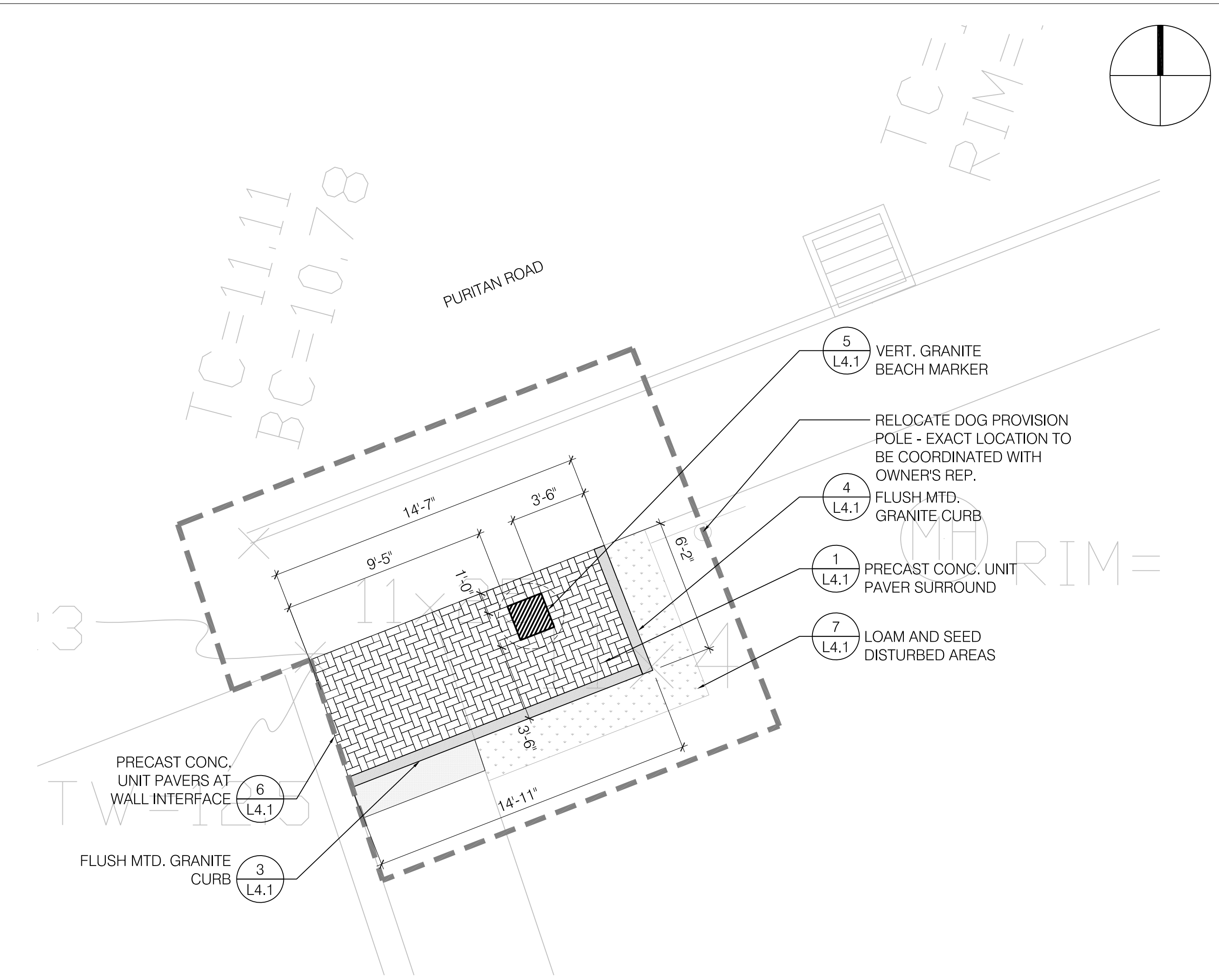

1 NEW OCEAN BEACH LOCATION
SCALE: 1/4" = 1'-0"

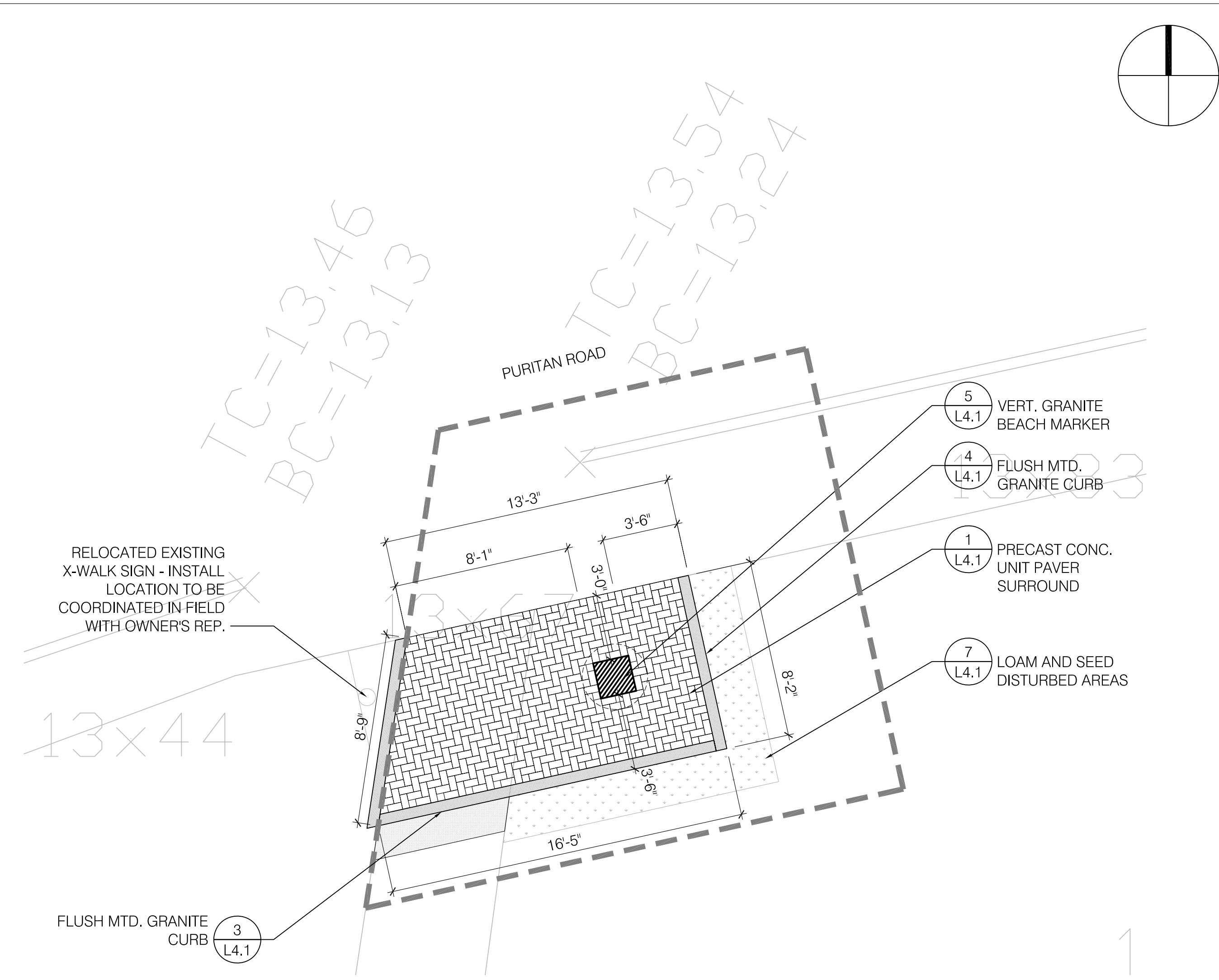

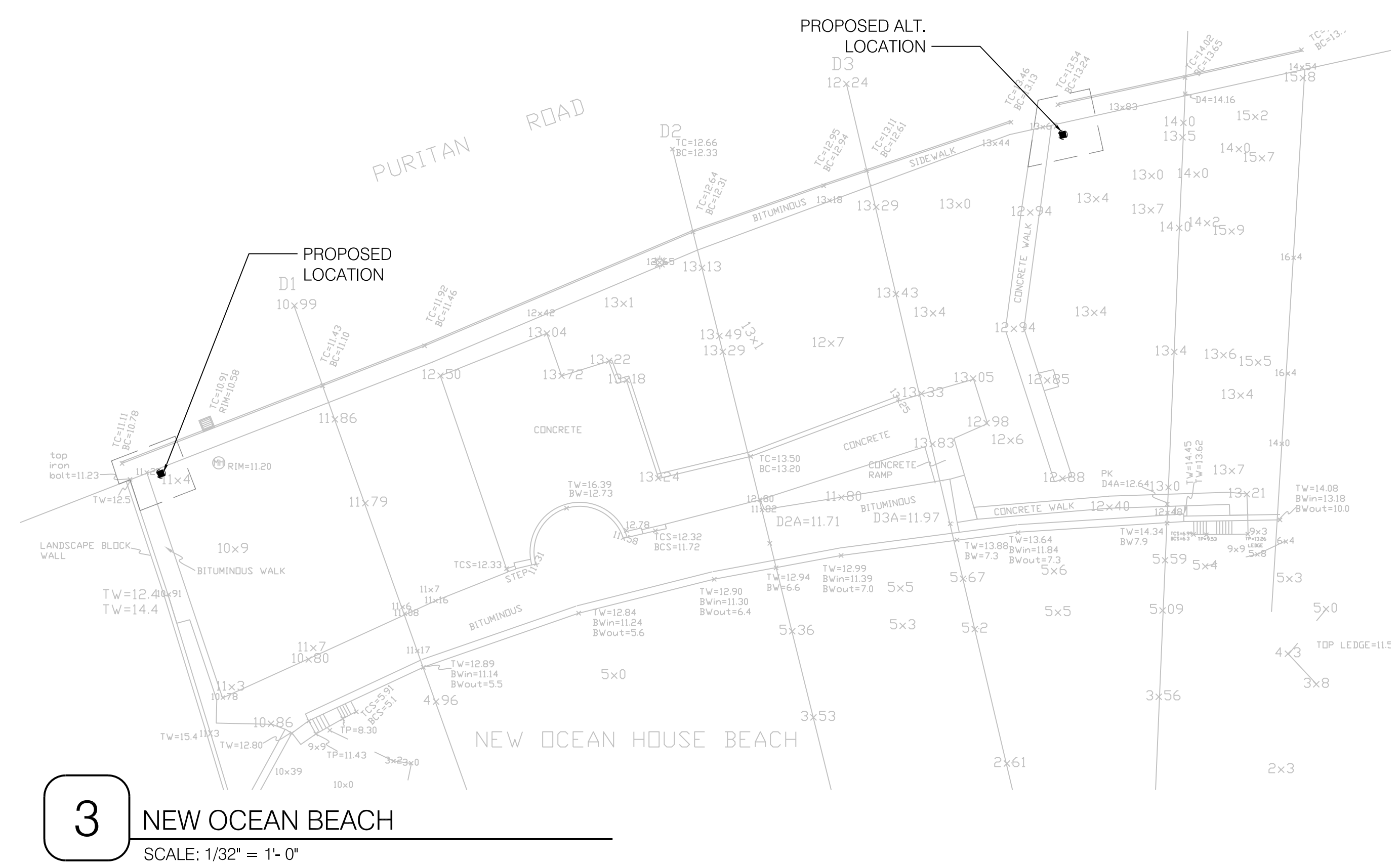

2 NEW OCEAN BEACH ALT. LOCATION
SCALE: 1/4" = 1'-0"

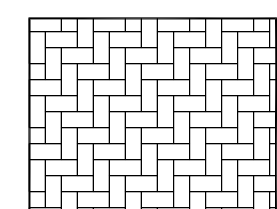
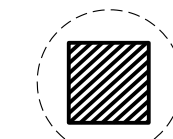

3 NEW OCEAN BEACH
SCALE: 1/32" = 1'-0"

LEGEND

-  PRECAST CONC. UNIT PAVERS
-  VERT. GRANITE BEACH MARKER
-  FLUSH MTD. GRANITE CURB
-  LIMIT OF WORK

CLIENT:

TOWN OF SWAMPSCOTT

22 MONUMENT AVE.
SWAMPSCOTT, MA, 01907

REVISIONS:

REV	DATE	NOTE

PROJECT:
SWAMPSCOTT WATERFRONT ACCESS PLAN

PURITAN ROAD
SWAMPSCOTT, MA, 01907

DRAWING:

WHALE'S & EISMAN'S BEACH MATERIALS PLAN

DRAWN: LP REVIEW: MK

SCALE:
AS NOTED



DATE:
07 JUNE 2019

SHEET:

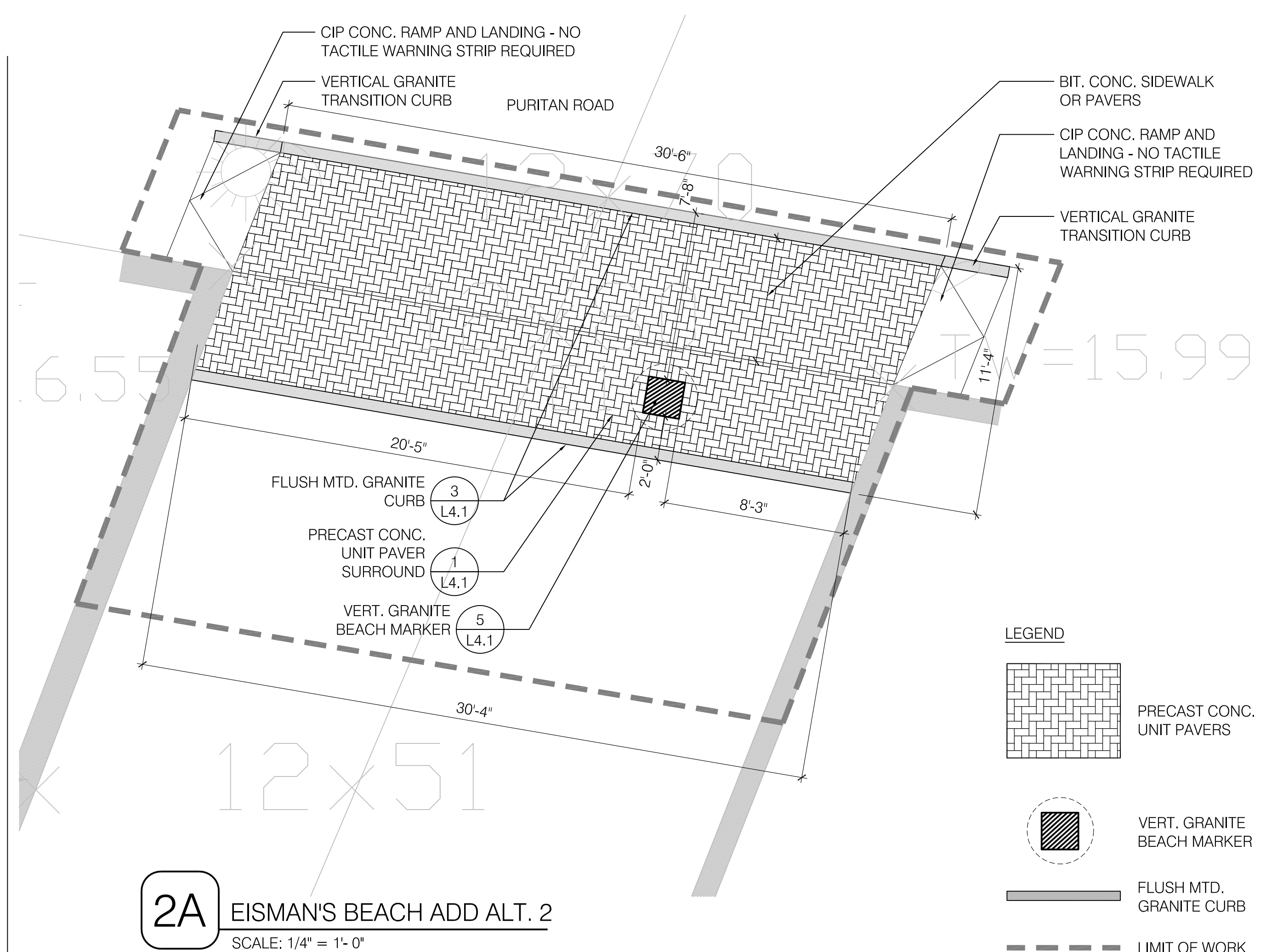
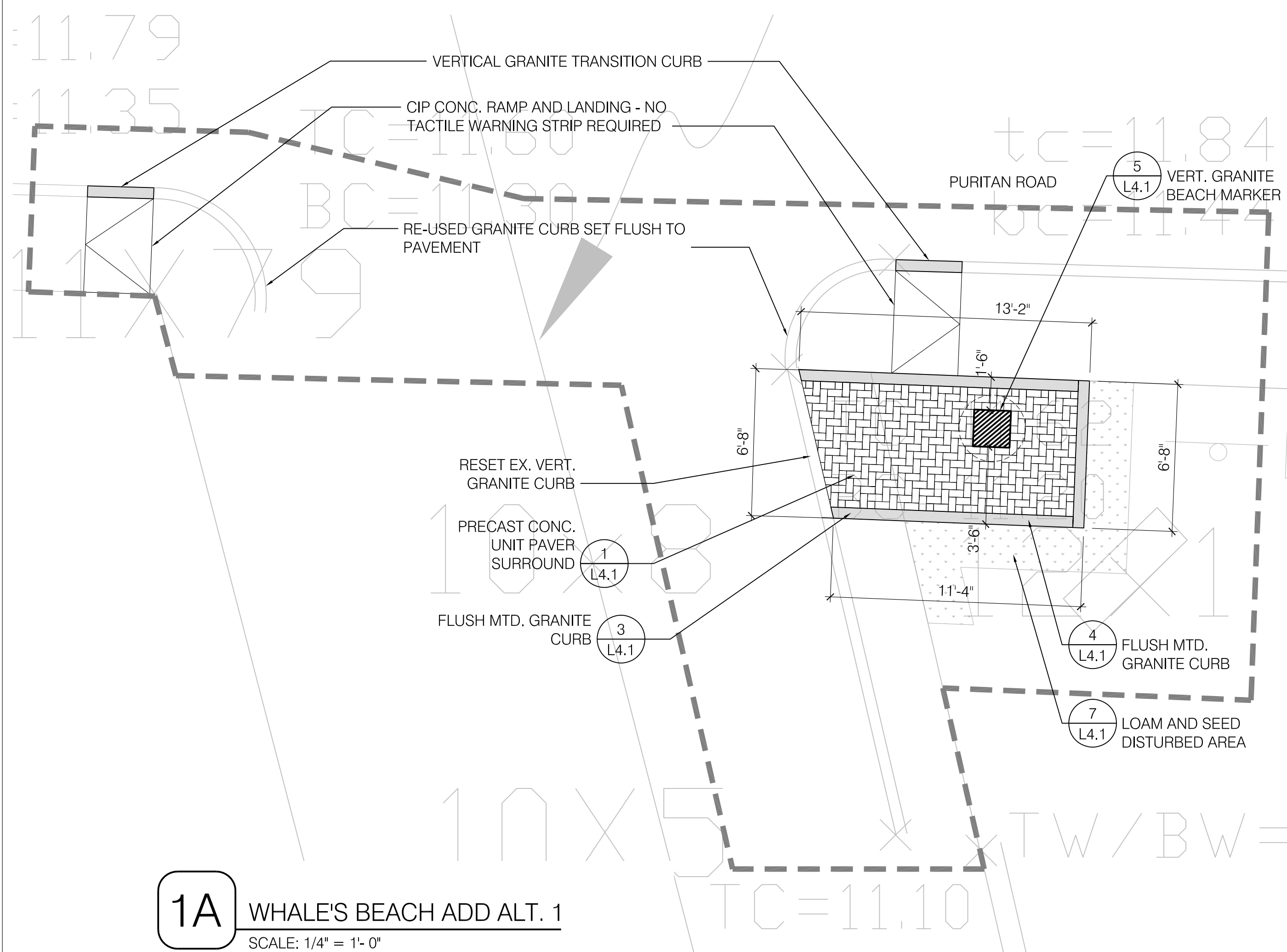
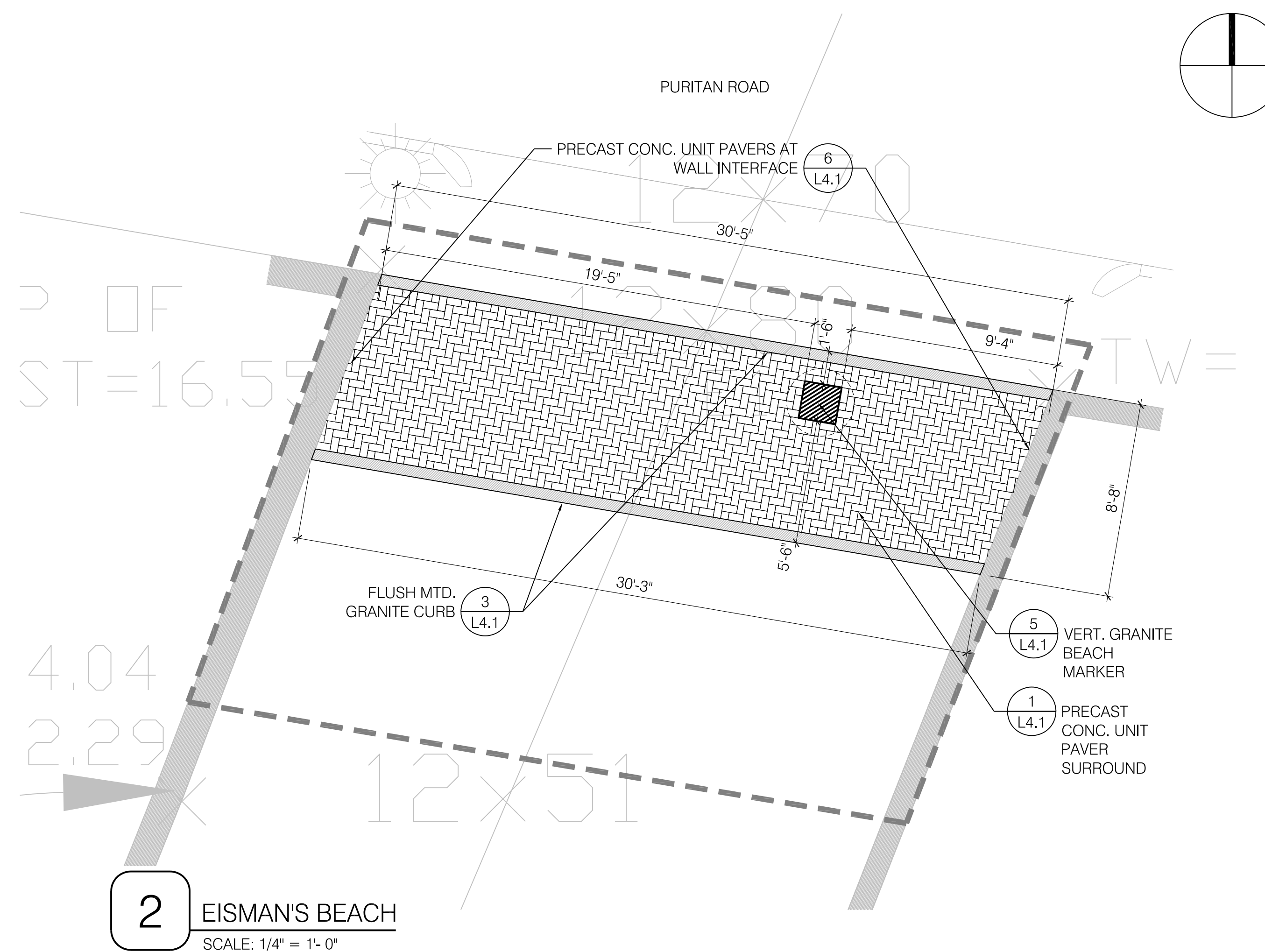
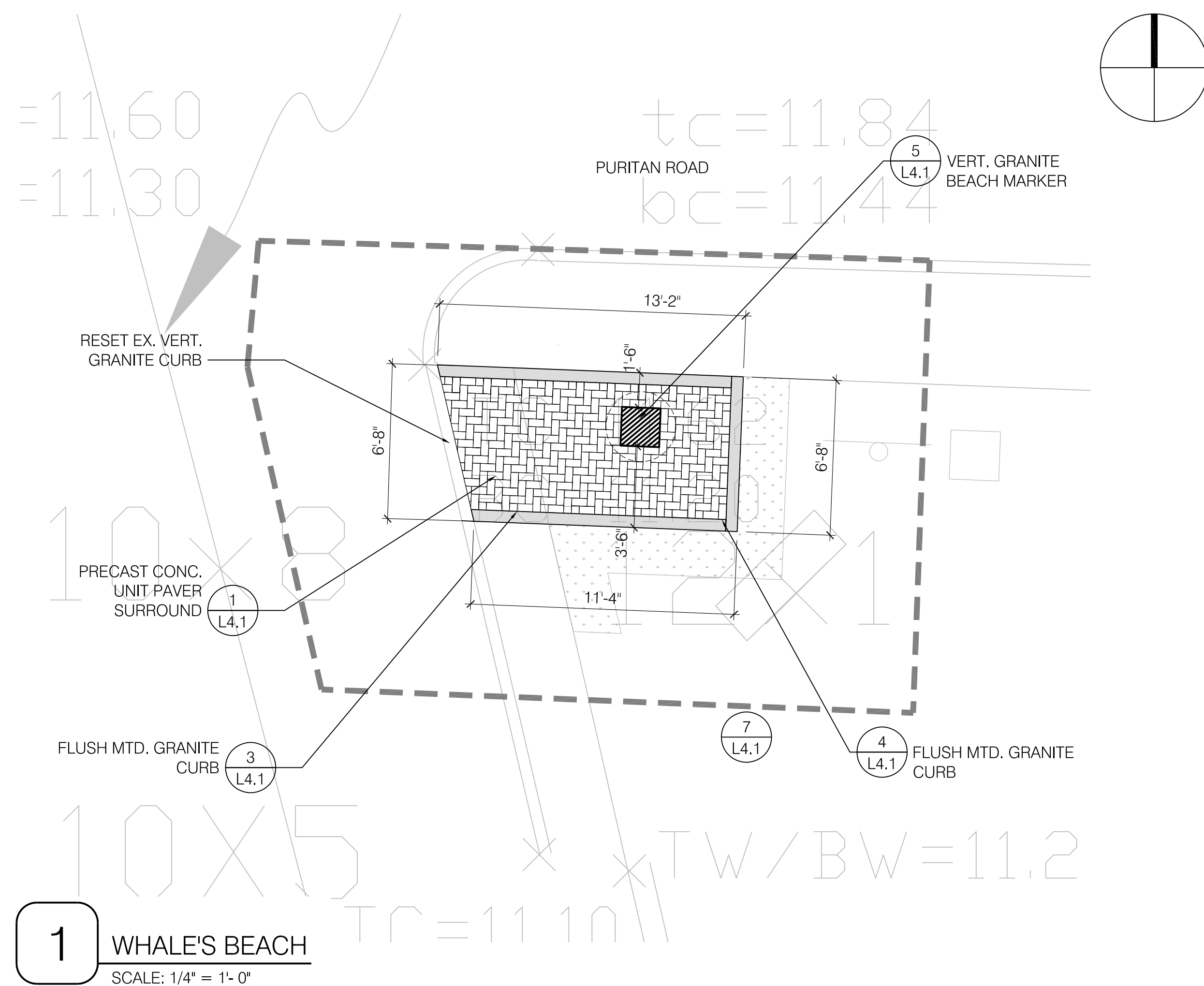
L3.2

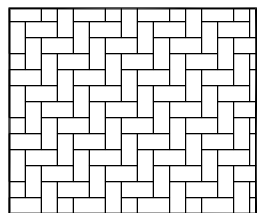
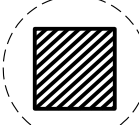
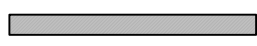

LEGEND

-  PRECAST CONC. UNIT PAVERS
-  VERT. GRANITE BEACH MARKER
-  FLUSH MTD. GRANITE CURB
-  LIMIT OF WORK

CLIENT:

TOWN OF SWAMPSCOTT

22 MONUMENT AVE.
SWAMPSCOTT, MA, 01907

REVISIONS:

REV	DATE	NOTE

PROJECT:
SWAMPSCOTT WATERFRONT ACCESS PLAN

PURITAN ROAD
SWAMPSCOTT, MA, 01907

DRAWING:

DETAILS

DRAWN: LP REVIEW: MK

SCALE: AS NOTED

DATE: 07 JUNE 2019

SHEET:

L4.1

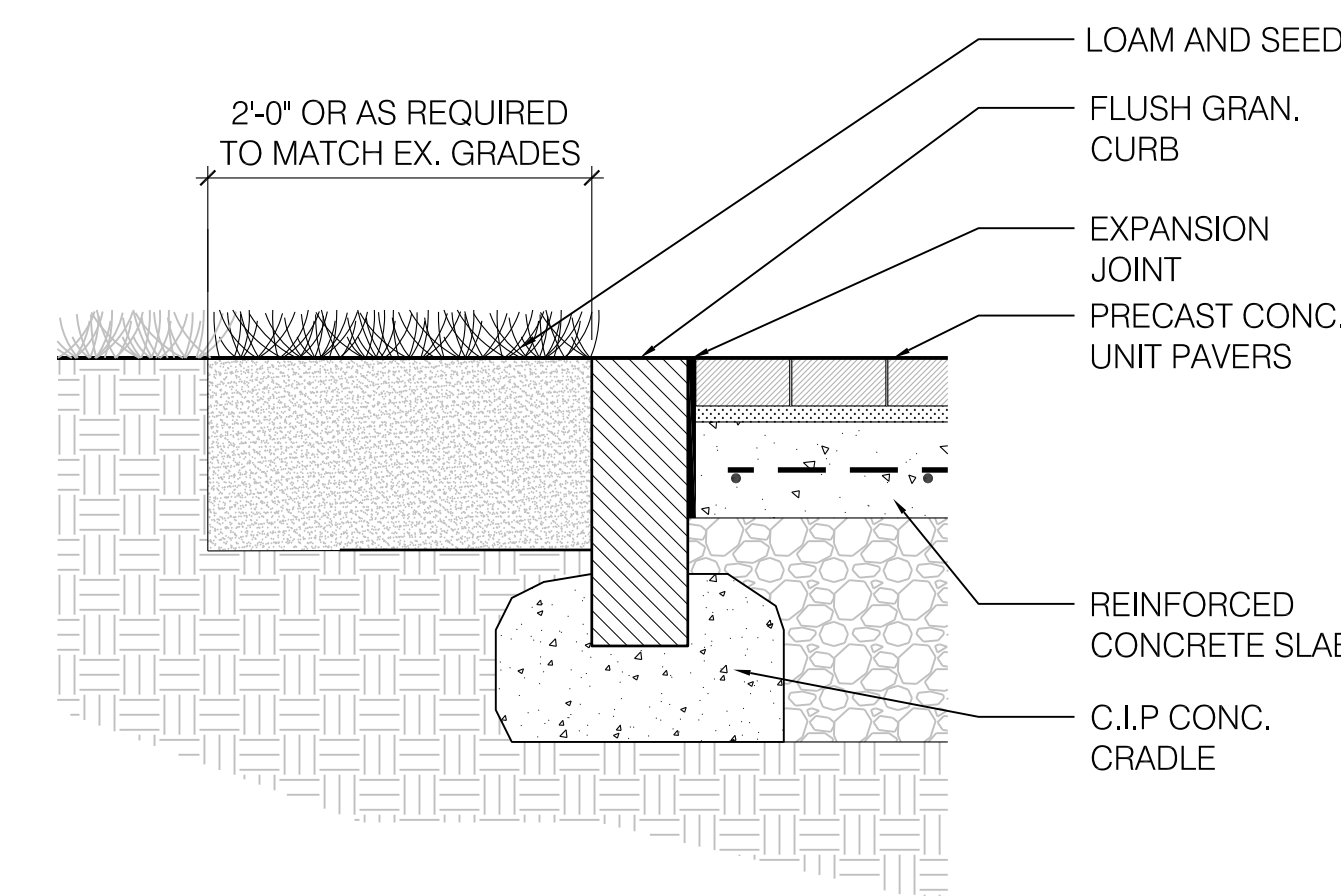

4 FLUSH GRAN CURB @ LAWN
SCALE: 1" = 1'-0"

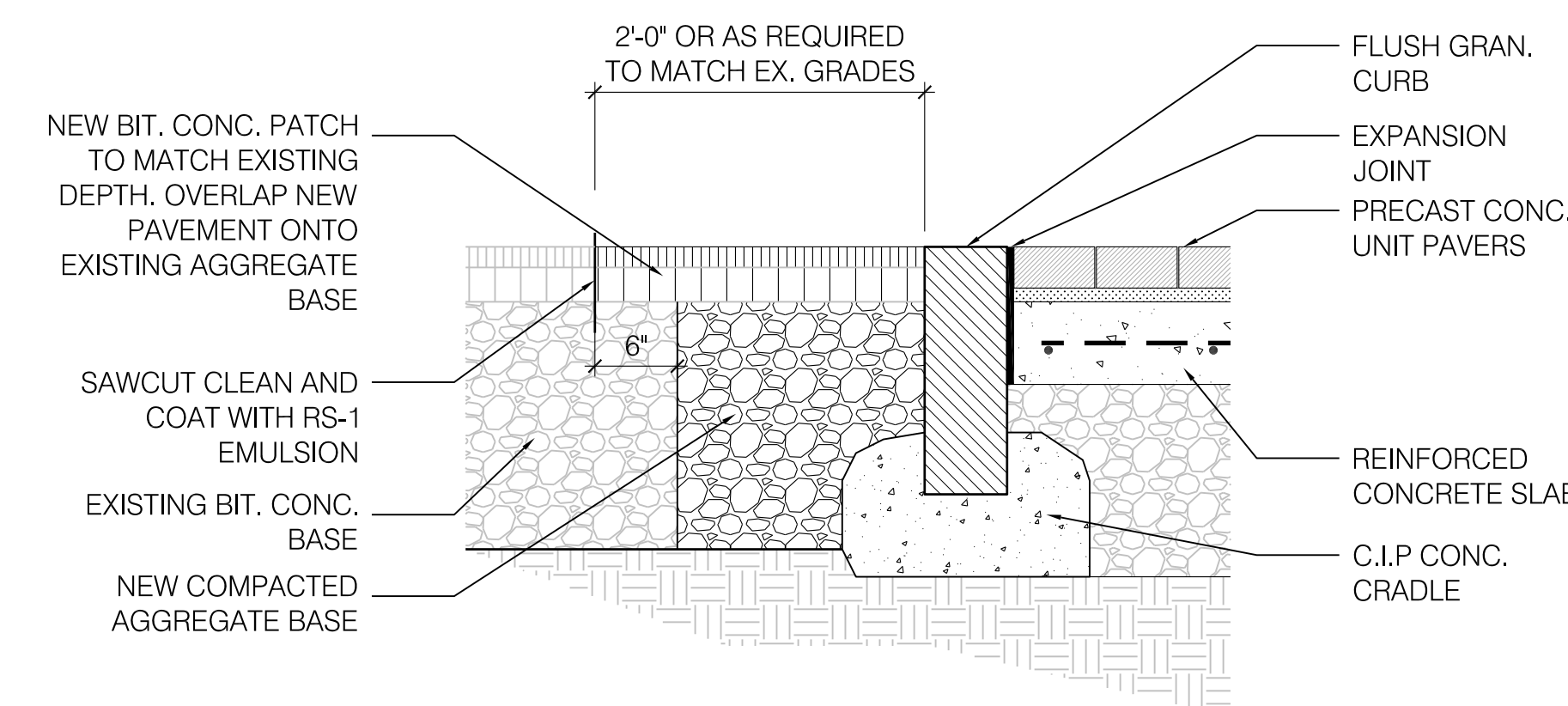

3 FLUSH GRAN CURB @ BIT CONC
SCALE: 1" = 1'-0"

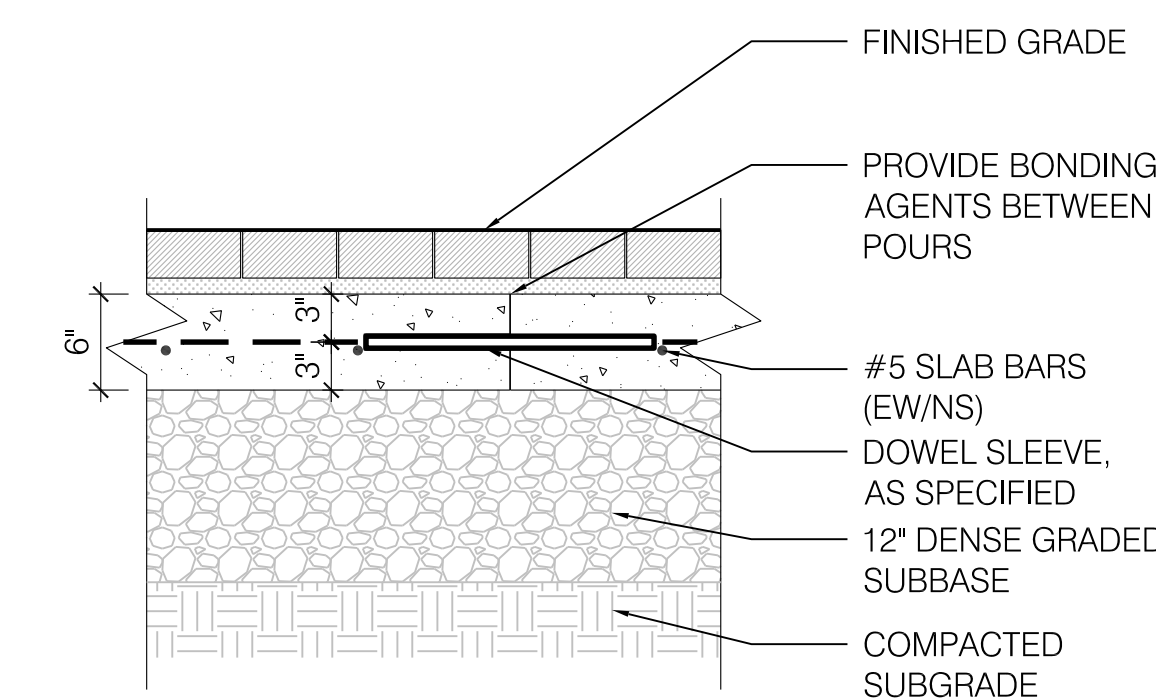

2 CIP CONC. SLAB CONST. JOINTS
SCALE: 1" = 1'-0"

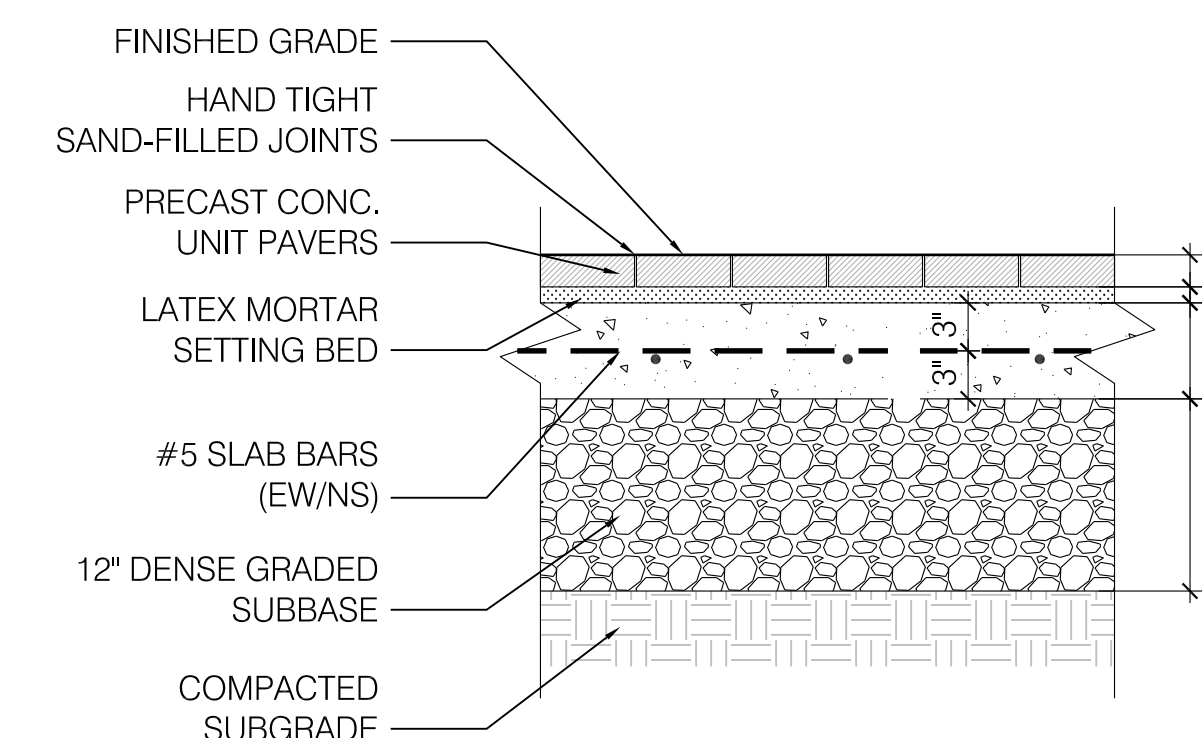

1 PRECAST CONC. UNIT PAVERS ON SLAB
SCALE: 1" = 1'-0"

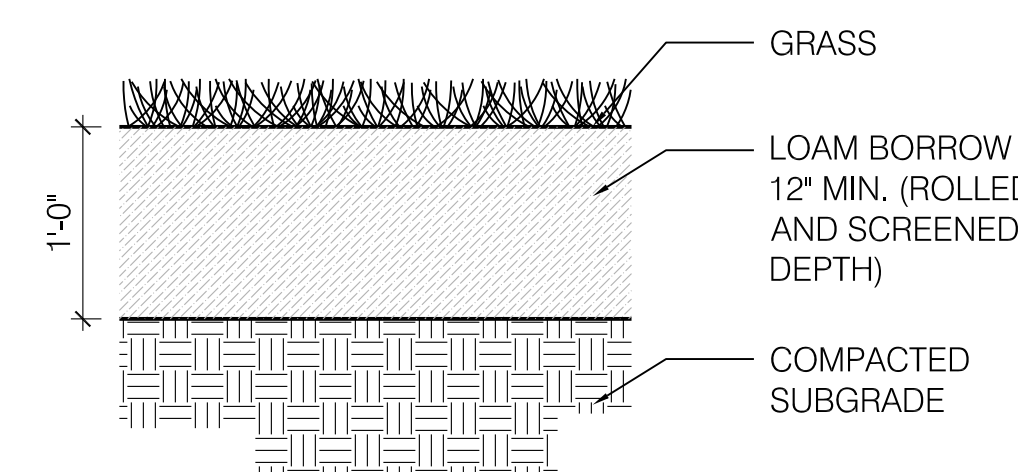

7 LOAM AND SEED
SCALE: 1" = 1'-0"

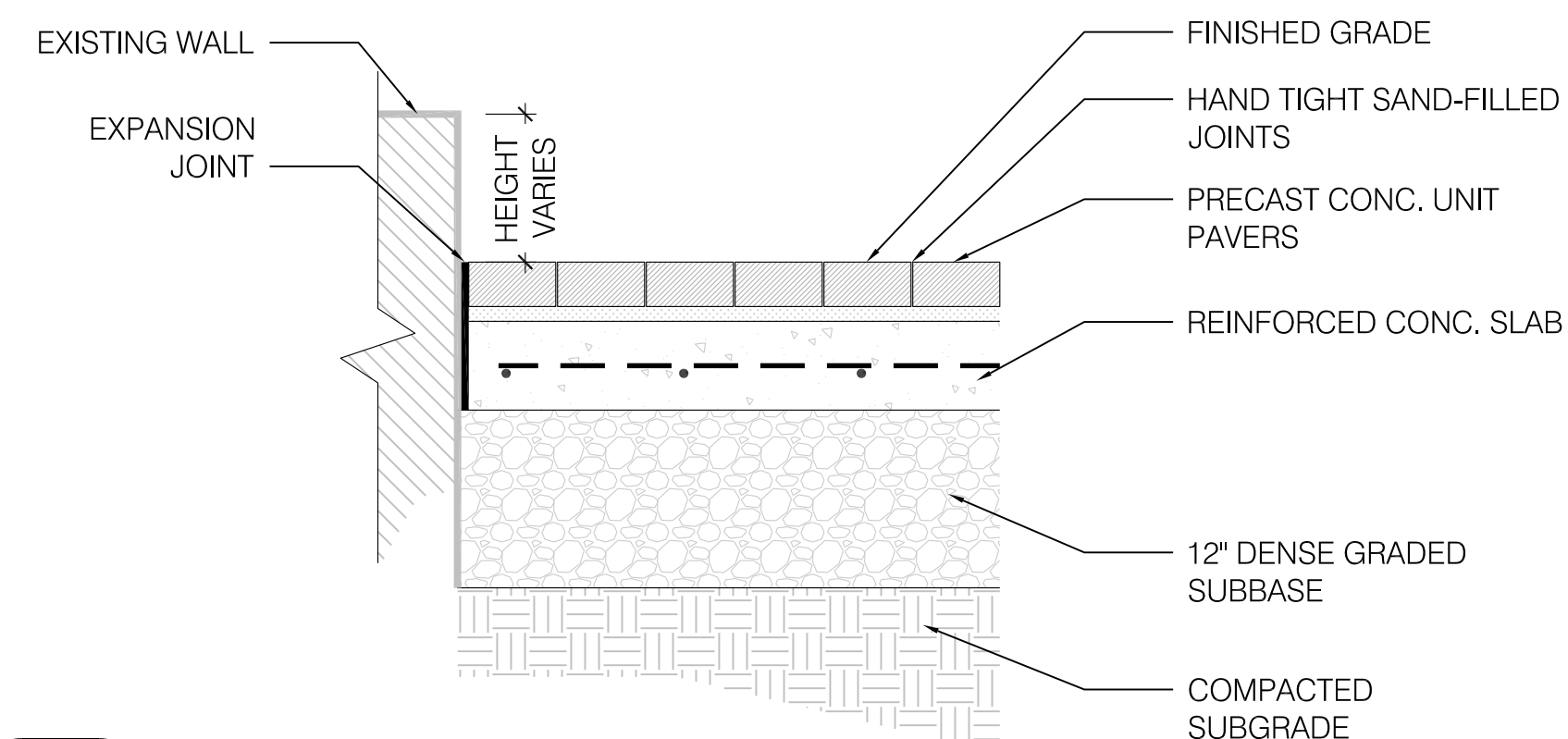

6 PRECAST CONC. UNIT PAVERS AT WALL INTERFACE
SCALE: 1" = 1'-0"

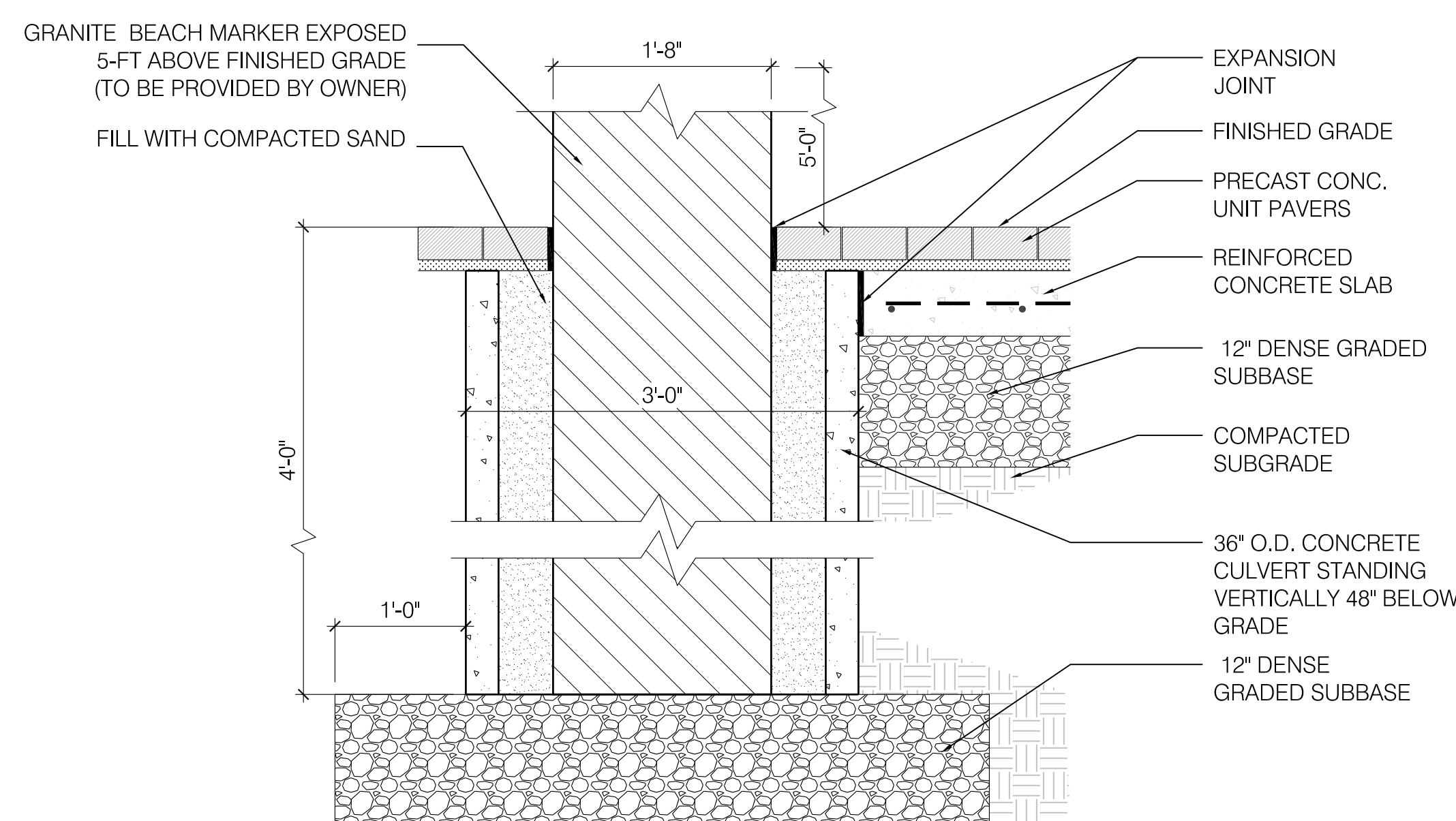

5 VERT. GRAN BEACH MARKER
SCALE: 1" = 1'-0"